



The Humber Valley Flyer



Visit us at www.hvrcf.org May, 2005

Swap Meet Tues May 3rd, 2005 @ 7:00 PM



Here's how to get there:
From the 401, take Keele north. Turn right on Sheppard, and follow Sheppard to the Downsview Park entrance and turn right on John Drury Drive.

Turn left at Carl Hall Road and continue over the railway tracks. The museum is on the right.

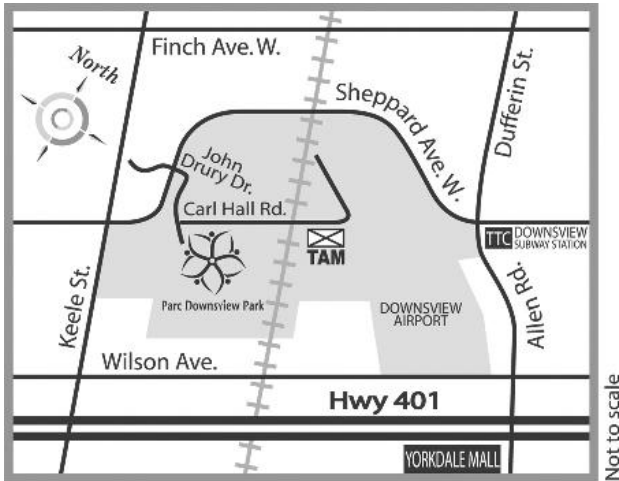

Not to scale

Student Instruction Starts May 5th

Ready – Get Set – Go! The flying season is here and the student program starts Thursday May 5th and continues every Tuesday and Thursday evening (weather permitting) starting around 6:00pm and ending at dusk.

There will be an instructors' meeting scheduled on the weekend of the 14th of May. Any members wishing to join the flight instruction team should contact Gary Del Bel Belluz.

Sat May 8th – Spring Season Opener and Field Cleanup – 10am

Please mark your calendars and make an extra effort to come out and start the spring flying season. The field is in pretty good shape so there will only be minor garbage clean up and filling of potholes. We still have topsoil from last year to repair the pit area and field perimeters. **Gary Del Bel Belluz** will be organizing the field cleanup day. Please come out to help and fly at the season opener!



Static Display and Prize Raffle – May 3rd

Because we are not having a beauty contest this year, it would be a shame not to show off your pride and joy. So bring it in to the May Swap Meet meeting and receive a raffle ticket for great prizes. All planes, all types and skill levels are eligible.

Can't wait any longer? The Humber Valley Multi-Club Swap Meet is Here – May 3rd

Toronto Aerospace Museum

We have invited other area clubs from the GTA to make this a **really big** event. So come out and sell your unneeded stuff or buy a bargain. The following clubs are participating:



- Humber Valley
- Toronto
- Richmond Hill
- Bramalea
- Ajax
- Pickering

For more information or to make sure and reserve a table, call Pat Knight at (416) 225-2687. Otherwise, just come out and bring whatever you have to sell!

NOTE: Admission is \$4.00 (Including HVRCF members)
All proceeds go to the TAM
Set up starts at 7:00pm
Sales start at 7:30pm

Experience Canadian aviation history at the museum like this beautiful Tiger Moth

- all included with your Swap Meet entrance fee!



Beauty contest cancelled in favor of static display and raffle for prizes!

Calendar of Upcoming Events

Tue May 3 rd	Multi-club swap meet at the TAM
Sat May 8 th	Field cleanup day and opening of the spring flying season – 10am
Thu May 5 th	Start of student instruction at the field 6:00pm
Sat Jun 11 th	Big Brother's Open House event free fly 10:00am to 2:00pm (Rain date: Sunday, June 12)
Sun Jul 10 th	Death Valley Dogfight 1/12 scale R/C combat - 10:00am to 4:00pm
August	HVRCF – IMAC aerobatic competition – date to be announced.
September	Fall Fun Fly - date to be announced.



Field Update

The metal storage container is now in place, and the mower should have arrived by the time you are reading this notice. The club has purchased a Cub Cadet tractor with a 24 horsepower Briggs and Stratton engine and



hydrostatic automatic transmission. It is equipped with a 50" cutting deck and 3 heavy duty cutting blades!

Last year there was member approval to roll the field at a cost of about \$300, however it was never done. Accordingly, The Executive decided to purchase an 800 lb roller at a cost of \$350. That is the maximum size roller than can be pulled by the tractor. We have been advised by the retailer that, if done at the appropriate time (i.e. after a couple days of rain), the roller will do an admirable job of smoothing the field. We have always struggled with the timing of rolling the field. This way we can roll it anytime we need - and at the right time after a rain.

Renewals Processing Update

Membership processing will now be done by David Plank. If you have not yet renewed, send in the 2005 form ASAP in order to fly this spring. An updated copy of the 2005 application form is attached. Note the addition of the Family Junior fee category. Common Dad! Take your son or daughter out flying this season! Forms and payment should be sent to:

David Plank, 764 Indian Road, Toronto, ON, M6P 2E5

Your Executive ...

President, David Plank	(416) 763 0082
Vice President, Gary Del Bel Belluz	(416) 741 8181
Secretary, Dan Paluzzi	(905) 303 0500
Program Director, Pat Knight	(416) 225-2687
Contest Director, Dave Sanders	(905) 271 3141
Treasurer, Agasthi Ranasinghe	(905) 761 2092
Field Officer, Gary Del Bel Belluz	(416) 741 8181
Past President, Tom Gottlieb	(416) 781 3189

Appointed Club Positions:

Editor, Tom Gottlieb	(416) 781 3189
Web Master, Barry Collingwood	(416) 925 6588
Librarian, Roy Gee	(416) 749 8793
Jr. Representative, Justin Gregoris	(905) 893 0763

Summer Fun Fly Discussion

The executive is discussing the possibility of replacing the summer Fun Fly with a later Fall Season Fun Fly in order to improve attendance. That way any members who go away for summer vacations in July and August will be able to attend. Bring up your suggestions with any club executive.

Mounting an Internal Switch

Mounting your receiver switch internally isn't too tough - here's one way. Just put in a piece of lite ply to mount the switch, drill out the hole in the switch as necessary to insert a piece of 1/16" music wire, and secure with 1/16" wheel collars.

Why mount the switch internally? Well - do it for looks mostly, especially for a scale model. Also there is less chance that an internal switch will get dirt, water, or fuel in it.

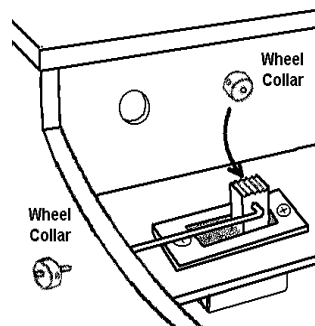

An Internal Switch

Note: Some modelers will mount the switch such that the OFF position is pushed in, and the ON position is pulled out. This lessens the chance that bumping it during handling will inadvertently turn the switch on, and run down your batteries.

The other theory is that it's better to push ON so that you won't inadvertently turn off your radio while launching or handling.

Simple Fueling

System for Cowled Engines

What is a good way to fuel and defuel a plane when the engine is cowled in and you can't reach the fuel lines? You can buy fuel line taps but often the commercial fuel fillers clog or leak air. And if they fail, you can have serious problems. Here is a simple alternative to tap into a fuel line.

The system shown here is certainly not the most aesthetically pleasing, but it is simple and reasonably foolproof. You just glue in a pair of short brass fuel tubes into the fuselage side and run the fuel feed line to the carb through the tubes. A short length of flex tubing on the outside of the plane completes the system.

You can then fuel or defuel by unhooking the short tubing, and connecting to the side that goes to the tank.

SIMPLE Fueling/Defueling -for cowled engines

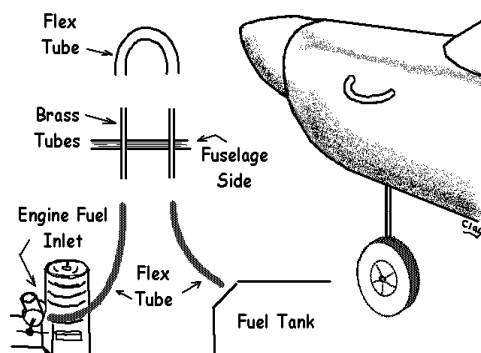

There is an added benefit - you can pinch the short outside loop to check your mixture setting, something you cannot do with the commercial fittings.